

3U OpenVPX 6-slot BKP3-DIS06-15.2.14-n Backplane

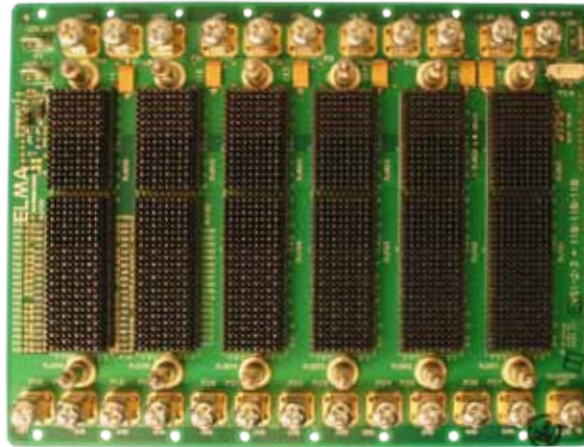

Description

VITA 46.0 is the core document for VPX and applies to all of the subsidiary documents. Therefore because our backplanes meet the requirements of VITA 46.0 they are designed to support all of the subsidiary documents for sRIO, PCI Express, Ethernet or Infiniband. This backplane is VITA 65 (OpenVPX) compliant for system interoperability.

A typical 3U VPX backplane offers much less potential I/O channels than 6U VPX. However, steps have been taken to ensure the architecture offers enough flexibility and functionality. Utilizing a twisted-ring topology versus a mesh topology allows for more I/O pins and ability to use mezzanines like XMC. A full mesh topology over 3U VPX would simply take up the vast majority of available pins. In the Bustronic 3U VPX backplane to 46.20 specifications, slot 6 has configurable thin pipe links for distributed Gigabit Ethernet to slot 1 through slot 5 and two fat pipes for rear I/O. In slots 1-5 any or all of the P1 thin pipes (x2 channels) assigned to the 46.20 control channel star can be reconfigured as rear I/O by removing zero ohm SMT shunts. In slots 1-5 all P2 differential pairs are available on the rear side for I/O.

The VPX Gigabit Ethernet Control Plane originally per VITA 46.20 (now part of the VITA 65 profile for this backplane) adds a GigE switch, providing a separate star or dual star network for out-of-band communication. This can be particularly important for system management, software and firmware upgrades, and initiating new processes on specific boards.

Features

- Compliant to ANSI/VITA 65-2010
- Compliant to the latest VITA 46 Specifications
- High-speed MultiGig connector
- Uses the rugged 3U-160 Eurocard form factor
- Channels A and B are arranged as 2 fat pipes (x4) channels configured as a twisted ring extending from slots 1 to 5
- Provides built in ESD ground protection in every slot
- Versions with or without GigE Control Plane
- Version with slot 6 not connected to other slots for use with RTM

Board Specifications

- 22-layer stripline design
- 2 oz. power and ground
- PCB FR-4 or equivalent
- PCB .212" thick

Mechanical Specifications

- 3U height
- 6 slots
- MultiGig RT-2 connectors

Coming Soon!

Rear View



Close-up of Power studs and fast-on power blades

3U OpenVPX 6-slot BKP3-DIS06-15.2.14-n Backplane

Line Drawing

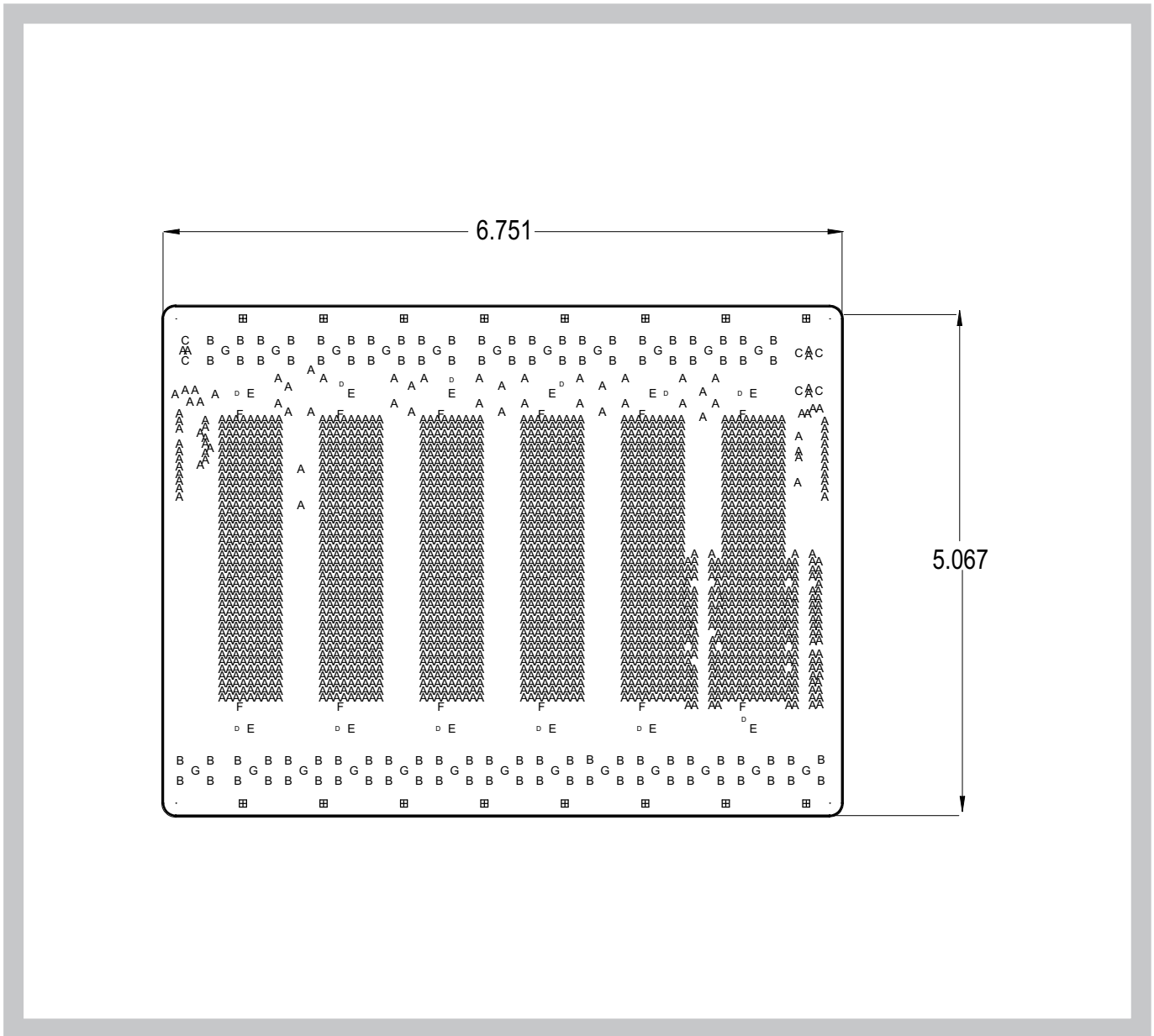

ORDER INFORMATION

Height	Total Slots	Description	Profile Number	Part Number
3U	6	VPX twisted ring with configurable Ethernet Control Plane channel Gbaud rate up to 6.25	BKP3-DIS06-15.2.14-3	10VX306SX6-1X11R
3U	6	VPX twisted ring with configurable Ethernet Control Plane channel Gbaud rate up to 6.25, no RTM connectors	BKP3-DIS06-15.2.14-3	10VX306SX6-1X10R

3U OpenVPX 6-slot BKP3-DIS06-15.2.14-n Backplane

Connector Positions

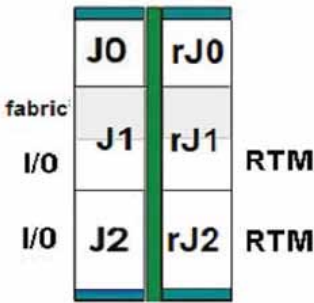

J0 Signal Assignments

	Row I	Row H	Row G	Row F	Row E	Row D	Row C	Row B	Row A
1	Vs1	Vs1	Vs1	Vs1	No Pad	Vs2	Vs2	Vs2	Vs2
2	Vs1	Vs1	Vs1	Vs1	No Pad	Vs2	Vs2	Vs2	Vs2
3	Vs3	Vs3	Vs3	Vs3	No Pad	Vs3	Vs3	Vs3	Vs3
4	GND	SM2	SM3	GND	-12V_Aux	GND	SYSRESET*	NVMRO	GND
5	GND	GAP*	GA4*	GND	3.3V_Aux	GND	SM0	SM1	GND
6	GND	GA3*	GA2*	GND	+12V_Aux	GND	GA1*	GA0*	GND
7	TCK	GND	GND	TDO	TDI	GND	GND	TMS	TRST*
8	GND	REF_CLK-	REF_CLK+	GND	GND	AUX_CLK-	AUX_CLK+	GND	GND

J1 Payload Signal Assignments

Plug-In Module P1	Row G	Row F	Row E		Row D	Row C	Row B		Row A
	Row i	Row h	Row g	Row f	Row e	Row d	Row c	Row b	Row a
Backplane J1	Row i	Row h	Row g	Row f	Row e	Row d	Row c	Row b	Row a
1	GDiscrete1	GND	GND-J1	DP01-TD0-	DP01-TD0+	GND	GND-J1	DP01-RD0-	DP01-RD0+
2	GND	DP01-TD1-	DP01-TD1+	GND-J1	GND	DP01-RD1-	DP01-RD1+	GND-J1	GND
3	P1-VBAT	GND	GND-J1	DP01-TD2-	DP01-TD2+	GND	GND-J1	DP01-RD2-	DP01-RD2+
4	GND	DP01-TD3-	DP01-TD3+	GND-J1	GND	DP01-RD3-	DP01-RD3+	GND-J1	GND
5	SYS_CON*	GND	GND-J1	DP02-TD0-	DP02-TD0+	GND	GND-J1	DP02-RD0-	DP02-RD0+
6	GND	DP02-TD1-	DP02-TD1+	GND-J1	GND	DP02-RD1-	DP02-RD1+	GND-J1	GND
7	Reserved	GND	GND-J1	DP02-TD2-	DP02-TD2+	GND	GND-J1	DP02-RD2-	DP02-RD2+
8	GND	DP02-TD3-	DP02-TD3+	GND-J1	GND	DP02-RD3-	DP02-RD3+	GND-J1	GND
9	UD	GND	GND-J1	UD	UD	GND	GND-J1	UD	UD
10	GND	UD	UD	GND-J1	GND	UD	UD	GND-J1	GND
11	UD	GND	GND-J1	UD	UD	GND	GND-J1	UD	UD
12	GND	UD	UD	GND-J1	GND	UD	UD	GND-J1	GND
13	UD	GND	GND-J1	CPTp02-DB-	CPTp02-DB+	GND	GND-J1	CPTp02-DA-	CPTp02-DA+
14	GND	CPTp02-DD-	CPTp02-DD+	GND-J1	GND	CPTp02-DC-	CPTp02-DC+	GND-J1	GND
15	Makeable Reset*	GND	GND-J1	CPTp01-DB-	CPTp01-DB+	GND	GND-J1	CPTp01-DA-	CPTp01-DA+
16	GND	CPTp01-DD-	CPTp01-DD+	GND-J1	GND	CPTp01-DC-	CPTp01-DC+	GND-J1	GND

J1 Switch Signal Assignments

Plug-In Module P1	Row G	Row F	Row E		Row D	Row C	Row B		Row A
	Row i	Row h	Row g	Row f	Row e	Row d	Row c	Row b	Row a
Backplane J1	Row i	Row h	Row g	Row f	Row e	Row d	Row c	Row b	Row a
1	GDiscrete1	GND	GND-J1	CP01-T0-	CP01-T0+	GND	GND-J1	CP01-RD-	CP01-RD+
2	GND	CP01-T1-	CP01-T1+	GND-J1	GND	CP01-R1-	CP01-R1+	GND-J1	GND
3	P1-VBAT	GND	GND-J1	CP01-T2-	CP01-T2+	GND	GND-J1	CP01-R2-	CP01-R2+
4	GND	CP01-T3-	CP01-T3+	GND-J1	GND	CP01-R3-	CP01-R3+	GND-J1	GND
5	SYS_CON*	GND	GND-J1	CP02-T0-	CP02-T0+	GND	GND-J1	CP02-R0-	CP02-R0+
6	GND	CP02-T1-	CP02-T1+	GND-J1	GND	CP02-R1-	CP02-R1+	GND-J1	GND
7	Reserved	GND	GND-J1	CP02-T2-	CP02-T2+	GND	GND-J1	CP02-R2-	CP02-R2+
8	GND	CP02-T3-	CP02-T3+	GND-J1	GND	CP02-R3-	CP02-R3+	GND-J1	GND
9	UD	GND	GND-J1	CPTp01-TD-	CPTp01-TD+	GND	GND-J1	CPTp01-RD-	CPTp01-RD+
10	GND	CPTp02-TD-	CPTp02-TD+	GND-J1	GND	CPTp02-RD-	CPTp02-RD+	GND-J1	GND
11	UD	GND	GND-J1	CPTp03-TD-	CPTp03-TD+	GND	GND-J1	CPTp03-RD-	CPTp03-RD+
12	GND	CPTp04-TD-	CPTp04-TD+	GND-J1	GND	CPTp04-RD-	CPTp04-RD+	GND-J1	GND
13	UD	GND	GND-J1	CPTp05-TD-	CPTp05-TD+	GND	GND-J1	CPTp05-RD-	CPTp05-RD+
14	GND	CPTp06-TD-	CPTp06-TD+	GND-J1	GND	CPTp06-RD-	CPTp06-RD+	GND-J1	GND
15	Makeable Reset*	GND	GND-J1	CPTp07-TD-	CPTp07-TD+	GND	GND-J1	CPTp07-RD-	CPTp07-RD+
16	GND	CPTp08-TD-	CPTp08-TD+	GND-J1	GND	CPTp08-RD-	CPTp08-RD+	GND-J1	GND

3U OpenVPX 6-slot BKP3-DIS06-15.2.14-n Backplane

J2/P2 Signal Assignments* (Slots 1-5)

Plug in Module P2-P6	Row G	Row F	Row E		Row D	Row C	Row B		Row A
	Row i	Row h	Even	Odd	Row e	Row d	Even	Odd	Row a
1	SEwafer1	GND	GND-J2	LN0-TD-	LN0-TD+	GND	GND-J2	LN0-RD-	LN0-RD+
2	GND	LN1-TD-	LN1-TD+	GND-J2	GND	LN1-RD-	LN1-RD+	GND-J2	GND
3	SEwafer3	GND	GND-J2	LN2-TD-	LN2-TD+	GND	GND-J2	LN2-RD-	LN2-RD+
4	GND	LN3-TD-	LN3-TD+	GND-J2	GND	LN3-RD-	LN3-RD+	GND-J2	GND
5	SEwafer5	GND	GND-J2	LN4-TD-	LN4-TD+	GND	GND-J2	LN4-RD-	LN4-RD+
6	GND	LN5-TD-	LN5-TD+	GND-J2	GND	LN5-RD-	LN5-RD+	GND-J2	GND
7	SEwafer7	GND	GND-J2	LN6-TD-	LN6-TD+	GND	GND-J2	LN6-RD-	LN6-RD+
8	GND	LN7-TD-	LN7-TD+	GND-J2	GND	LN7-RD-	LN7-RD+	GND-J2	GND
9	SEwafer9	GND	GND-J2	LN8-TD-	LN8-TD+	GND	GND-J2	LN8-RD-	LN8-RD+
10	GND	LN9-TD-	LN9-TD+	GND-J2	GND	LN9-RD-	LN9-RD+	GND-J2	GND
11	SEwafer11	GND	GND-J2	LN10-TD-	LN10-TD+	GND	GND-J2	LN10-RD-	LN10-RD+
12	GND	LN11-TD-	LN11-TD+	GND-J2	GND	LN11-RD-	LN11-RD+	GND-J2	GND
13	SEwafer13	GND	GND-J2	LN12-TD-	LN12-TD+	GND	GND-J2	LN12-RD-	LN12-RD+
14	GND	LN13-TD-	LN13-TD+	GND-J2	GND	LN13-RD-	LN13-RD+	GND-J2	GND
15	SEwafer15	GND	GND-J2	LN14-TD-	LN14-TD+	GND	GND-J2	LN14-RD-	LN14-RD+
16	GND	LN15-TD-	LN15-TD+	GND-J2	GND	LN15-RD-	LN15-RD+	GND-J2	GND

* Any signal pins pass through the rear

J2/P2 Switch Signal Assignments (Slot 6)

Plug-In Module P2	Row G	Row F	Row E		Row D	Row C	Row B		Row A
	Row i	Row h	Even	Odd	Row e	Row d	Even	Odd	Row a
1	UD	GND	GND-J2	CPutp09-TD-	CPutp09-TD+	GND	GND-J2	CPutp09-RD-	CPutp09-RD+
2	GND	CPutp10-TD-	CPutp10-TD+	GND-J2	GND	CPutp10-RD-	CPutp10-RD+	GND-J2	GND
3	UD	GND	GND-J2	CPutp11-TD-	CPutp11-TD+	GND	GND-J2	CPutp11-RD-	CPutp11-RD+
4	GND	CPutp12-TD-	CPutp12-TD+	GND-J2	GND	CPutp12-RD-	CPutp12-RD+	GND-J2	GND
5	UD	GND	GND-J2	CPutp13-TD-	CPutp13-TD+	GND	GND-J2	CPutp13-RD-	CPutp13-RD+
6	GND	CPutp14-TD-	CPutp14-TD+	GND-J2	GND	CPutp14-RD-	CPutp14-RD+	GND-J2	GND
7	UD	GND	GND-J2	CPutp15-TD-	CPutp15-TD+	GND	GND-J2	CPutp15-RD-	CPutp15-RD+
8	GND	CPutp16-TD-	CPutp16-TD+	GND-J2	GND	CPutp16-RD-	CPutp16-RD+	GND-J2	GND
9	UD	GND	GND-J2	CPutp17-TD-	CPutp17-TD+	GND	GND-J2	CPutp17-RD-	CPutp17-RD+
10	GND	CPutp18-TD-	CPutp18-TD+	GND-J2	GND	CPutp18-RD-	CPutp18-RD+	GND-J2	GND
11	UD	GND	GND-J2	CPutp19-TD-	CPutp19-TD+	GND	GND-J2	CPutp19-RD-	CPutp19-RD+
12	GND	CPutp20-TD-	CPutp20-TD+	GND-J2	GND	CPutp20-RD-	CPutp20-RD+	GND-J2	GND
13	UD	GND	GND-J2	CPutp21-TD-	CPutp21-TD+	GND	GND-J2	CPutp21-RD-	CPutp21-RD+
14	GND	CPutp22-TD-	CPutp22-TD+	GND-J2	GND	CPutp22-RD-	CPutp22-RD+	GND-J2	GND
15	UD	GND	GND-J2	CPutp23-TD-	CPutp23-TD+	GND	GND-J2	CPutp23-RD-	CPutp23-RD+
16	GND	CPutp24-TD-	CPutp24-TD+	GND-J2	GND	CPutp24-RD-	CPutp24-RD+	GND-J2	GND

3U OpenVPX 6-slot BKP3-DIS06-15.2.14-n Backplane

Port Mapping

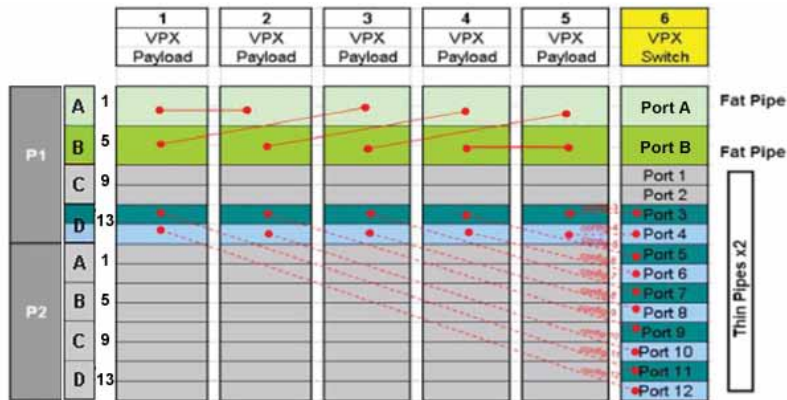

Ports A and B in slots 1-5 are fat pipes implemented via one twisted ring as the primary VITA 46 fabric. The fabric may be 10G Ethernet (10GBASE KX-4), sRIO, or PCIe. Slot 6 is a switch slot for a thin pipe, redundant dual star, or distributed GigE per VITA 46.20. The GigE is configurable at each of the slots 1-5 so that any individual slot could utilize ports in J1 rows 9-12 for rear I/O if desired. Port A and port B in slot 6 have 10G Ethernet rear I/O.

Backplane Topology

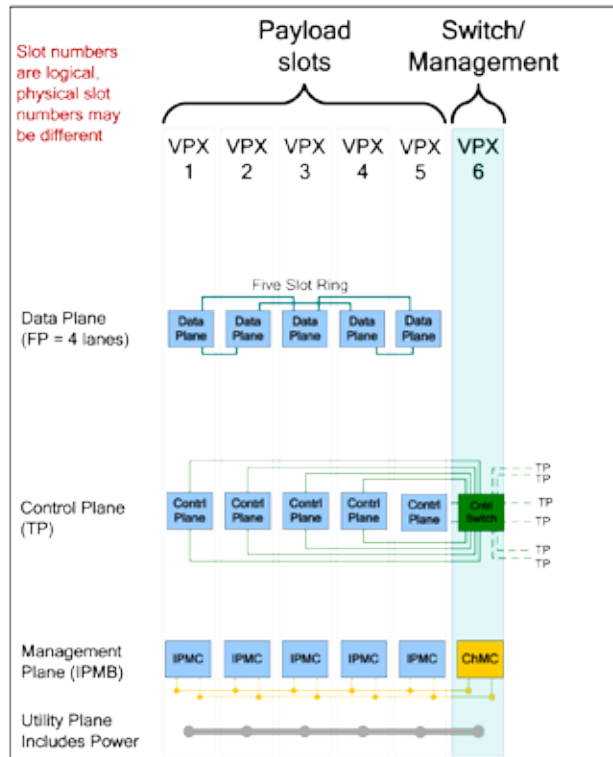

Backplane Profile

Profile name	Mechanical		Slot Profiles and Section		Channel Gbaud Rate	
	Pitch (in)	RTM Conn	Payload	Switch	Control Plane	Data Plane
BKP3-DIS06-15.2.14-1	1.0	VITA 46.10	SLT3-PAY-2F2T-14.2.5	SLT3-SWH-16T-14.4.6	1.25	3.125
BKP3-DIS06-15.2.14-2	1.0	VITA 46.10	SLT3-PAY-2F2T-14.2.5	SLT3-SWH-16T-14.4.6	1.25	5.0
BKP3-DIS06-15.2.14-3	1.0	VITA 46.10	SLT3-PAY-2F2T-14.2.5	SLT3-SWH-16T-14.4.6	1.25	6.25

3U OpenVPX 6-slot BKP3-DIS06-15.2.14-n Backplane

Payload Slot Profile

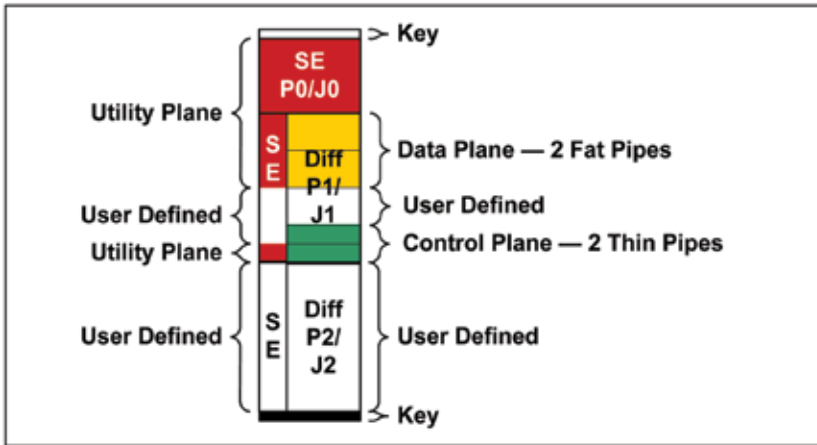

SLT3-PAY-2F2T-14.2.5

Switch Slot Profile

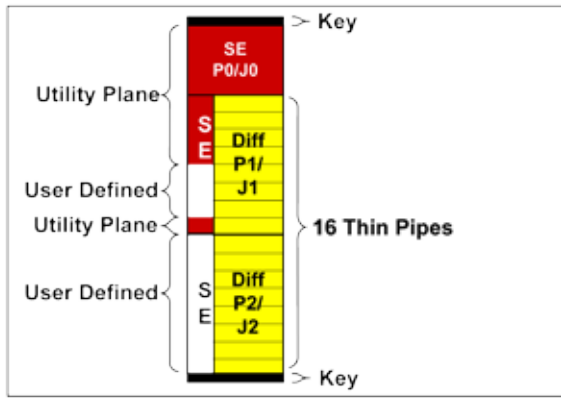

SLT3-SWH-16T-14.4.6

Related Products from Elma Electronic:

- System Platforms – need a chassis for your backplane?
- VPX Embedded Computing Products – SBCs, Switches, Storage, and More



Did you know we also offer with this OpenVPX backplane?

- VPX Extenders, load boards, RTMs, test modules
- Thermal or backplane simulation/test, paint/silkscreen, customization, integration