

EASYPLUG cPCI BACKPLANES

MECHANICAL SPECIFICATIONS

- 3U - 8 slots
- 6U - 8, 14, 16 slots
- 9U - 2, 4, 6, 8 slots
- 64-bit (32-bit capable)

BOARD SPECIFICATIONS

- 8-layer board (12-layer for H.110)
- 2 oz. copper power and ground
- PCB UL recognized 94V-0
- PCB FR-4 or equivalent
- PCB .125" thick, (.149") 14-slot

The Bustronic CompactPCI backplane series is designed to be fully compliant with PICMG standards. The EasyPlug line features Positronic 47-pin power connectors on the backplane. The monolithic backplanes have pluggable modules that eliminate cabling in the chassis, reducing system costs and allowing more swappability. The 3U and 6U cPCI versions are standardly with the power connectors in a vertically oriented position. The 9U cPCI are standardly with the power connectors in a horizontally oriented position.

The new EasyPlug CompactPCI backplane line allows pluggability for power supplies, fan trays, utility headers, and shelf managers. This reduces mean-time-to-repair (MTTR) and time-consuming cabling costs. We have provided all the standard features required for full compatibility, including all pin connections for bussed signal lines and all defined power and ground pins connected to their respective planes. User defined VI/O is standard. All standard CPCI backplanes conform to the PICMG basic specification 2.0 R2.1 and Hot Swap specification 2.1 R1.0 All Bustronic backplanes are designed to maximize performance, minimize noise, and give the customer the most reliable, cost-effective products possible. To achieve superior performance, we construct the board in eight layers (12 layers for H.110) three signal layers, five power ground planes. We incorporate a full stripline design, generously distributed decoupling capacitors, and 2 oz. power and ground planes. Our standard design with two 2oz. copper ground planes fully shield the backplane, minimize EMI/RFI emissions susceptibility, minimize crosstalk, and maximize power distribution.

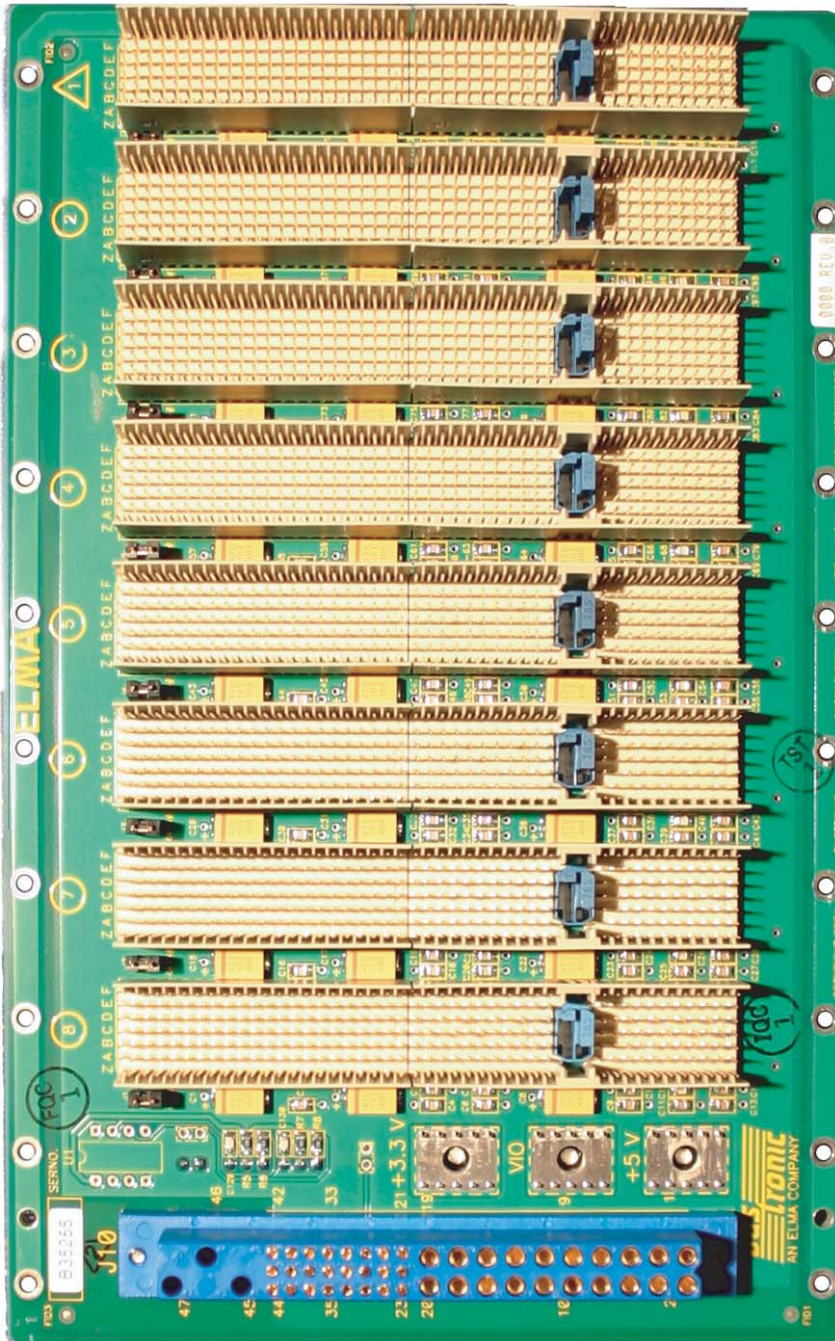

FEATURES

- Conforms to PICMG basic specification 2.0 R3.0
- Conforms to PICMG Hot Swap specification 2.1 R1.0
- Versions conforming to PICMG H.110 Computer Telephony specification 2.5 R1.0
- Right or left justified system slot
- 47-pin Positronic power supply connectors – vertically mounted in 3U, 6U versions and horizontally mounted in 9U versions.
- Virtually zero crosstalk

User Manual for Bridgeable Backplanes

Background

CompactPCI bridging was developed to circumvent the 9-load limitation on 8-slot boards. The CPU board generates two loads and the I/O boards generate one load each. The bridgeboards put an extra load on a slot; therefore, the segments are limited to seven loads. Bridgeboards provide up to 256 CompactPCI segments in a system. The segment containing the CPU board is called the primary or upstream segment. The segment on the other side of the bridgeboard is called the secondary or downstream segment.

Installation

14-slot cPCI: The bridgeboard is installed on the rear side of the backplane, covering slots 5 through 8. Place the unit on slot 5 rP1 and rP2 and slot 8 rP1 and rP2.

16-slot cPCI: The bridgeboard is installed on the rear side of the backplane, covering slots 4 through 9. Place the unit on slot 4 rP1 and rP2 and slot 9 rP1 and rP2

Notes

JP1 - - JP1 is the jumper for +5V operation and JP2 for +3.3V operation.

	H9	IDSEL2-1	SYSEN2-2	REQ_P, GNT_P, CLK_P
Without Bridge	this jumper is mounted	this jumper is mounted	this jumper is mounted	this jumper are mounted
With Bridge	this jumper is left blank	this jumper is left blank	this jumper is left blank	this jumper are left blank

Bridge

32-bit, 64-bit

33 Mhz

PCB height 95.10mm

PCB width 78.96mm

PCB thickness 2.70mm

The bridge is 4 slots wide and covers P1 and P2 on the rear of the backplane. On the 14-slot backplane, it plugs into rear slot 5 and slot 8.

Ordering Information

Slots	Height	Width In	Thickness	Description	Order Number
8	3U	7.999	.125"	One 47-pin, vertical, rt. justified	103CPCR308
8	6U	8.000	.125"	One 47-pin, vertical, rt. justified	103CPCR608
14	6U	15.967	.149"	Three 47-pin, vertical, rt. justified	103CPCI614
14	6U	15.967	.169"	Three 47-pin, vertical, H.110, rt. justified	103CTEL614
16	6U	15.967	.129"	Two 47-pin, vertical, lt. justified	103CPCL616
16	6U	15.967	.157"	Two 47-pin, vertical, H.110, lt. justified	103CTLL616
2	9U	1.670*	TBD	One 47-pin, horizontal, lt. justified	103CPCI902
2	9U	1.670*	TBD	One 47-pin, horizontal, H.110, lt. justified	103CTEL902
4	9U	3.180*	TBD	Two 47-pin, horizontal, lt. justified	103CPCI904
4	9U	3.180*	TBD	Two 47-pin, horizontal, H.110, lt. justified	103CTEL904
6	9U	4.700*	TBD	Two 47-pin, horizontal, lt. justified	103CPCI906
6	9U	4.700*	TBD	Two 47-pin, horizontal, H.110, lt. justified	103CTEL906
8	9U	6.380*	TBD	Three 47-pin, horizontal, lt. justified	103CPCI908
8	9U	6.380*	TBD	Three 47-pin, horizontal, H.110, lt. justified	103CTEL908
		* estimates			

DESIGN ELEMENTS

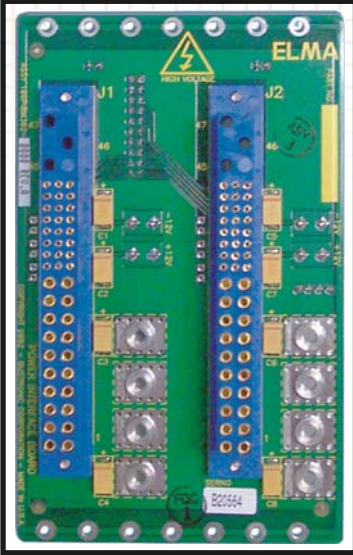

Power Distribution

The Bustronic EasyPlug CPCI backplane series features the 47-pin Positronic power connector. The 3U and 6U cPCI versions are standardly with the power connectors in a vertically oriented position. The 9U cPCI are standardly with the power connectors in a horizontally oriented position.

Signal Layout

The Bustronic design conforms to the PICMG basic specification 2.0 R3.0 and basic Hot Swap specifications 2.0 R1.0. Some versions comply with the PICMG 2.5 R 1.0 Computer Telephony and/or PICMG 2.16 Packet Switching specifications. A minimum stub length is utilized in routing and interconnecting to the signal traces. Our design techniques avoid crosstalk and noise caused by inadequate ground and power.

Jumpering

Jumpers can be installed to close a circuit. The backplane has labeled areas for jumper installation. The following applies to all of Bustronic's CompactPCI and H.110 backplanes in 2-8 slot sizes. Configurations with 2-5 slots have an addition jumper consideration, the M66EN# jumper.

64-EN# Jumper

If the jumper is installed, 64-EN# P2-B5 (see Hot Swap specification, PICMG 2.1) is ground, and 64-bit boards will initialize for 64-bit operation. If the jumper is not installed, 64-EN# is open, and 64-bit boards will initialize for 32-bit operation.

2-5 Slot Backplanes Only:

M66EN# Jumper

If the jumper is installed M66EN# P1-D21 is ground and the backplane operates in 33MHz mode. If the jumper is not installed M66EN# is bussed and the backplane operates in 66MHz mode.