



VPX 6U CONDUCTION COOLED LOAD CARD  
User Manual

# Table of Contents

## Contents

Introduction .....	1
Product Features .....	1
Front Panel Control & Monitoring .....	2
Side Panel Control & Monitoring .....	3
Operating Instructions .....	4
a. Go-No-Go LEDs .....	4
b. External Voltage Measurements .....	5
c. Remote Load Control .....	6
d. Remote Voltage/Signal Monitoring .....	7
e. Temperature Monitoring .....	8
f. Over-Temperature Protection .....	9

## Appendix

VPX 6U Module Connector Pin Diagrams .....	10-14
Power Wafer Current Ratings .....	15

## Introduction

### Introduction

In a given system platform, there is a general need of a hardware that can test the power handling and dissipation capabilities within a given environment. Keeping this in mind ELMA Electronic Inc. has developed a Conduction Cooled Load Card in 6U form factor to test the conduction cooled VPX based system platforms.

VPX 6U Conduction Cooled Load Card (herein referred to as "Load Card") gives a step-loading capability to the user to test the VPX based system power supplies under a given environment. It can act as a thermal load to evaluate the system's thermal performance. The user can either monitor the power supply voltage at various loads by monitoring the Go-No-Go LEDs on the front panel or perform an external measurement with a multimeter or scope.

### Product Features

The Load Card is built around the electronic load elements as compared to traditional resistive load approach. The loads are BJT-based constant current sources. This allows for the high power load elements to fit in a compact space. Given below is the list of features of the Load Card.

- A total load capacity of 150W is provided using six VPX power supplies.
- A stepped load control is provided by user accessible jumpers on the side of the Load Card.
- Six visual bi-color Go-No-Go LEDs for Vs1=12V, Vs2=12V, Vs3=5V, +12V\_Aux, -12V\_Aux and 3.3V\_Aux are provided.
- Seven test point outputs are provided to monitor the voltage externally via a multimeter or a scope. SYSRESET signal is provided on a separate test point.
- Two K-Type thermocouple outputs are provided on DSUB-15 to monitor temperature of thermal management interfaces independently.
- The above mentioned seven test point outputs are also provided on DSUB-15 connector for remote monitoring.
- Remote control of the electronic load elements using external voltage source is provided.
- Operating temperature range is between -40°C to 70°C.
- Built in over-temperature protection.
- The design is based on the ANSI/VITA 46.0 and the ANSI/VITA 48.2 specification and fully compatible with OpenVPX (VITA 65 Specification) designs.
- The Load Card has 5HP pitch.

### Front/Side Panel Control and Monitoring

Based on the Load Card functionality the front panel controls can be grouped in six categories as shown in figure 1 and figure 2.

- Go-No-Go LEDs
- External Voltage Measurements
- Temperature Monitoring
- Remote Load Control
- Remote Voltage/Signal Monitoring
- Local Load Stepping

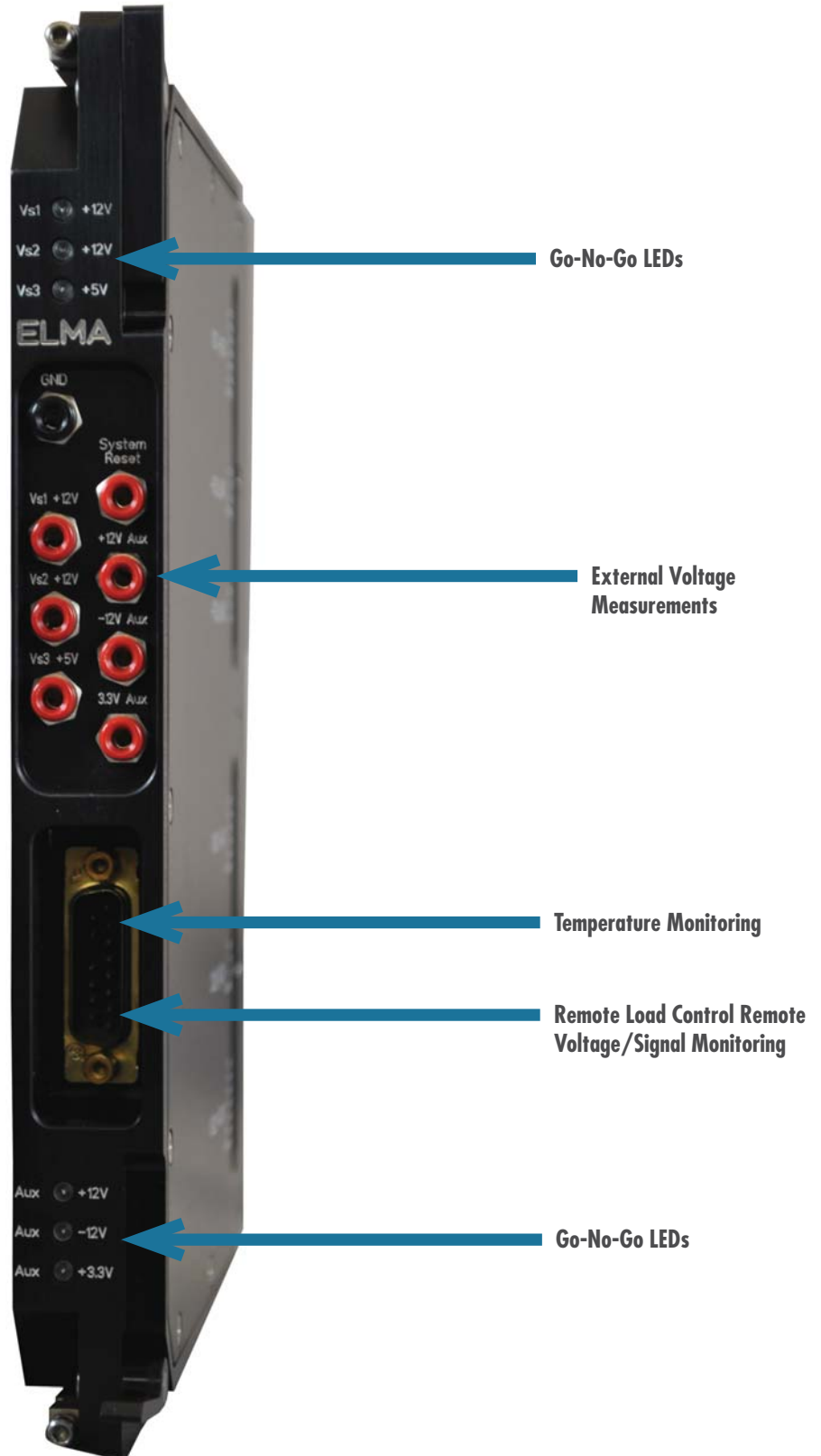

**Figure 1**

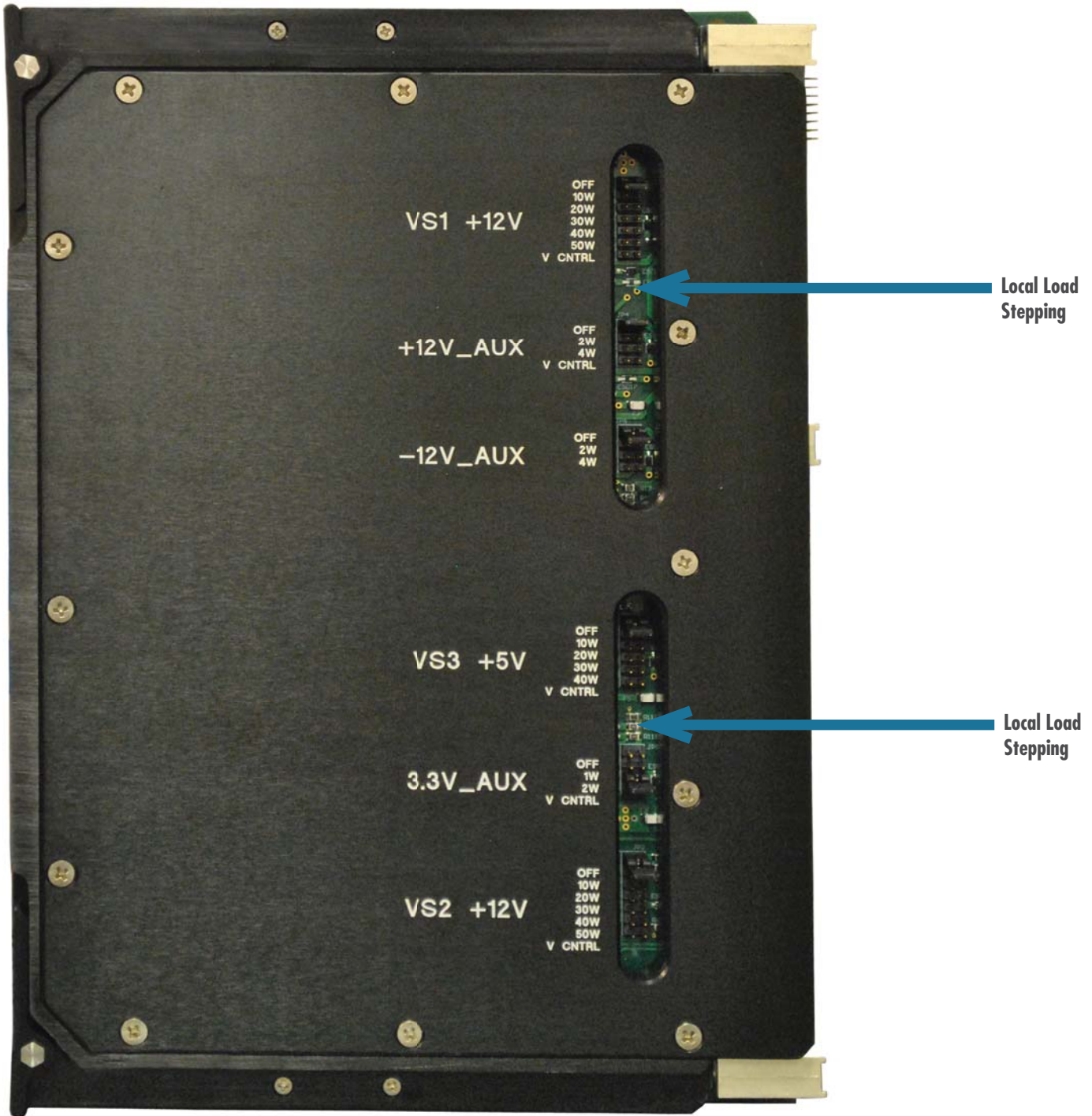

**Figure 2**

The operation of the Load Card is described based on the grouping of the control and monitoring sections shown in Figure 1 and Figure 2.

## Go-No-Go LEDs

The Load Card has six window voltage monitor circuits to monitor six VPX power supplies. Each circuit monitors its own voltage window per ANSI/VITA 46.0. The Load Card continuously monitors the voltages and compares them against the minimum and maximum limits set in the hardware. If any of the six VPX system voltages are out of range then the corresponding Go-No-Go LED will go RED. If all the voltages are within the range then the corresponding Go-No-Go LEDs will be GREEN. Table 3 below indicates the valid voltage limits on all six VPX supplies per ANSI/VITA 46.0 specification. Table 1 below indicates the voltage limits.

Front Panel VPX PSU Voltage Designators	Voltage Lower Limit	Voltage Upper Limit
Vs1 12V	11.4V	12.6V
Vs2 12V	11.4V	12.6V
Vs3 5V	4.875V	5.25V
+12V_Aux	11.4V	12.6V
-12V_Aux	-12.6V	-11.4V
3.3V_Aux	3.135V	3.465V

**Table 1**

## External Voltage Measurements

The test points provided on the front panel provides the voltage measurement points for all the six VPX power supplies. There are total of seven RED test points. Six test points are for voltage measurements and the seventh test point is provided to monitor the SYSRESET signal. The BLACK test jack is the GND reference for all the test points. Table 2 below shows the nominal voltage outputs on the test points.

Front Panel VPX PSU Voltage Designators	Voltage Lower Limit	Voltage Nominal	Voltage Upper Limit
Vs1 12V	11.4V	12V	12.6V
Vs2 12V	11.4V	12V	12.6V
Vs3 5V	4.875V	5V	5.25V
+12V_Aux	11.4V	12V	12.6V
-12V_Aux	-12.6V	-12V	-11.4V
3.3V_Aux	3.135V	3.3V	3.465V
SYSRESET	N/A	2.94V	N/A

**Table 2**

*Note: The voltage output limits are defined by ANSI/VITA 46.0.*

The size of the test points is selected to mate with the standard Fluke multimeter probes.

## Local Load Stepping

Local Load Stepping jumpers allows the loading of each of the six VPX power supplies independently. One jumper is provided for each header to ensure that only one step is set at a time for each supply header. Table 3 below provides all the load values at each header location when the jumper is placed on it.

VPX Voltage Name	OFF Jumper	10W Jumper	20W Jumper	30W Jumper	40W Jumper	50W Jumper
Vs1+12V	0W	10W	20W	30W	40W	50W
Vs2+12V	0W	10W	20W	30W	40W	50W
Vs3+5V	0W	10W	20W	30W	40W	N/A
	OFF Jumper	2W Jumper	4W Jumper			
+12V_Aux	0W	2W	4W			4W
-12V_Aux	0W	2W	4W			4W
	OFF Jumper	1W Jumper	2W Jumper			
3.3V_Aux	0W	1W	2W			2W

**Table 3**

For example, to set a load of 30W on voltage Vs1= +12V, first locate the header next to silkscreen marking Vs1 +12V. Then insert the jumper in the location labeled 30W. If no load is needed on the voltage Vs1 +12V then the jumper should be inserted in the location labeled OFF.

**Warning: Placing multiple jumpers on any header can damage the electronic load.**

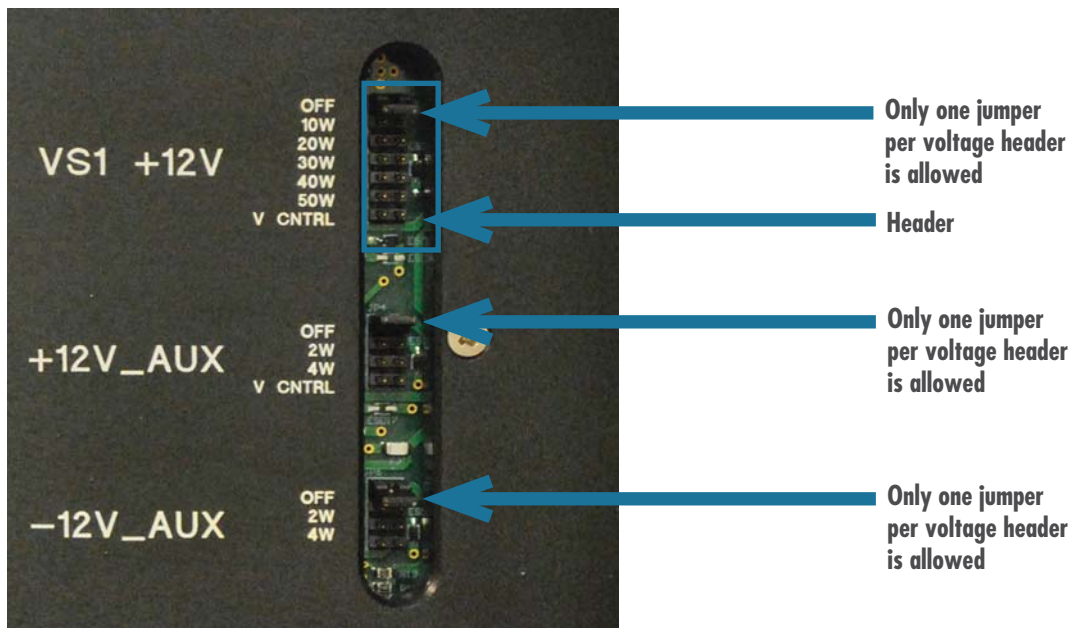

**Figure 3**

## Remote Load Control

Along with Local Load Stepping an option to remotely control the loads via external voltage is provided. This option is provided to test an enclosed chassis where there will be no access to Local Load Stepping jumpers. This control provides variable wattage steps anywhere from 0W to 146W using external voltage source.

In order to use the remote load control feature, set the Local Load Stepping jumpers labeled V CNTRL for all the VPX supply voltages that need to be remotely controlled. Local Load Stepping on the VPX supplies that are not set for remote control can still work in local mode. Connect an external 0V to 5V variable PSU to pins 12 and 13 on DBSUB-15, where pin 12 connects to the GND, and pin 13 connects to the positive voltage. The external PSU should be able to source 20mA of current. The graph in figure 4 shows the relationship between the load wattage and V CNTRL voltage.

**Warning: Applying more than 5V to V CNTRL can overheat and damage the loads.**

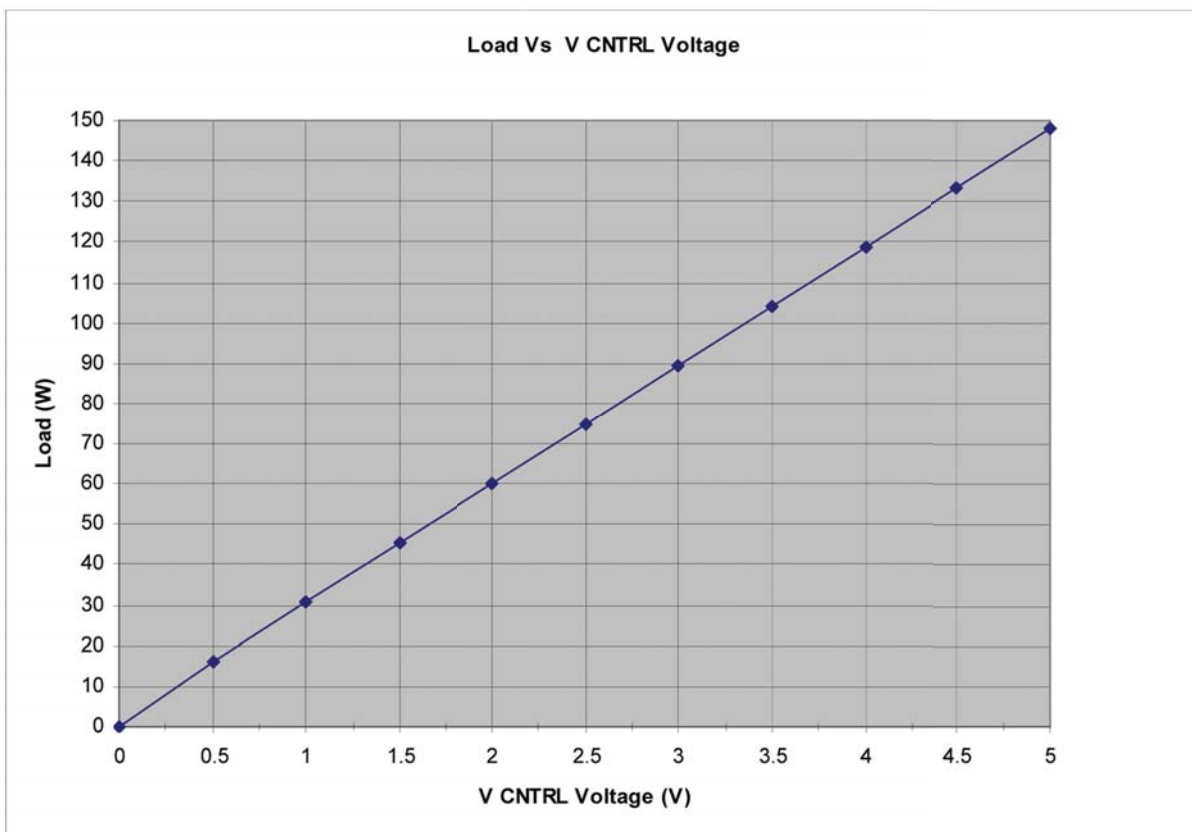

Figure 4

*Note: The -12V\_Aux supply is not available for remote control but can be used in local mode during remote control.*

## Remote Voltage/Signal Monitoring

VPX supply voltages and SYSRESET signal can be monitored remotely from an enclosed chassis. All the signals are pinned on the DSUB-15 connector. Table 4 provides the DSUB-15 connector pin out.

Pin Name	Signal
1	CHROMEGA(+) ( White Pin, Yellow Wire, Top Thermocouple)
2	CHROMEGA(+) ( White Pin, Yellow Wire, Top Thermocouple)
3	-12V Aux (Remote Voltage Monitoring)
4	3.3V Aux (Remote Voltage Monitoring)
5	+12V Aux (Remote Voltage Monitoring)
6	Vs3 +5V (Remote Voltage Monitoring)
7	Vs1 +12V (Remote Voltage Monitoring)
8	Vs2 +12V (Remote Voltage Monitoring)
9	Vs2 +12V (Remote Voltage Monitoring)
10	ALOMEGA(-) (Green Pin, Red Wire, Bottom Thermocouple)
11	No Connection
12	V CNTRL GND (Voltage Control GND)
13	V CNTRL (Voltage Control)
14	GND (Remote Voltage/Signal Monitoring GND)
15	SYSRESET (Remote Signal Monitoring)

**Table 4**

Any standard DSUB-15 mating female connector and pins can be used to connect to the DSUB-15 connector on the load card. The only exception is the set of pins used for K-Type thermocouples. This is discussed in the next section.

## Temperature Monitoring

The thermal impedance of the thermal management interfaces is very critical in order to transfer all the heat generated by plug-in modules. Therefore two K-Type thermocouples are placed inside each thermal management interface to monitor their temperature. Any standard off-the-shelf K-Type thermocouple acquisition hardware can be used to record the temperature for analysis. The thermocouple output connections are provided on the DSUB-15 connector using K-Type thermocouple crimps. When making a harness to connect to the thermocouples mating pins, the K-Type extension wire with K-Type crimps must be used. Using regular crimps and wire to interface to the thermocouple on DSUB-15 connector would give incorrect temperature readings. Table 5 provides the recommended crimp and wire part numbers available from Omega.

Part Description	OMEGA Part Number
CHROMEGA(+) K-Type Crimp	SMTC-CH-S
ALOMEGA(-) K-Type Crimp	SMTC-AL-S
Extension Wire K-Type	FF-K-24-25

**Table 5**

### Over Temperature Protection

Each Load Card has an over temperature protection feature which shuts off the loads in case of excessive heating. The temperature switch used on the load card has a trip point set at 110°C.

## VPX 6U Module Connector Pin Diagrams

Tables 1 to 13 below are the pin outs of VPX 6U Module connectors based on ANSI/VITA 46.0 specification.

### P0 Connector Pin Out

	Wafer Type	Row G	Row F	Row E	Row D	Row C	Row B	Row A
1	Power	Vs1	Vs1	Vs1	No Pad	Vs2	Vs2	Vs2
2	Power	Vs1	Vs1	Vs1	No Pad	Vs2	Vs2	Vs2
3	Power	Vs3	Vs3	Vs3	No Pad	Vs3	Vs3	Vs3
4	Single-ended	SM2	SM3	GND	-12V AUX	GND	SYSRESET*	NVMRO
5	Single-ended	GAP*	GA4*	GND	3.3V AUX	GND	SM0	SM1
6	Single-ended	GA3*	GA2*	GND	+12V AUX	GND	GA1*	GA0*
7	Differential	TCK	GND	IDO	IDI	GND	TMS	TRST*
8	Differential	GND	REF_CLK-	REF_CLK+	GND	RES_BUS-	RES_BUS+	GND

Table 1

### P1 Connector Pin Out

	Row G	Row F	Row E	Row D	Row C	Row B	Row A
1	P1-RES_BUS_SE	GND	P1-DP1-	P1-DP1+	GND	P1-DP0-	P1-DP0+
2	GND	P1-DP3-	P1-DP3+	GND	P1-DP2-	P1-DP2+	GND
3	P1-VBAT	GND	P1-DP5-	P1-DP5+	GND	P1-DP4-	P1-DP4+
4	GND	P1-DP7-	P1-DP7+	GND	P1-DP6-	P1-DP6+	GND
5	SYS_CON*	GND	P1-DP9-	P1-DP9+	GND	P1-DP8-	P1-DP8+
6	GND	P1-DP11-	P1-DP11+	GND	P1-DP10-	P1-DP10+	GND
7	P1-REF_CLK_SE	GND	P1-DP13-	P1-DP13+	GND	P1-DP12-	P1-DP12+
8	GND	P1-DP15-	P1-DP15+	GND	P1-DP14-	P1-DP14+	GND
9	P1-SE4	GND	P1-DP17-	P1-DP17+	GND	P1-DP16-	P1-DP16+
10	GND	P1-DP19-	P1-DP19+	GND	P1-DP18-	P1-DP18+	GND
11	P1-SE5	GND	P1-DP21-	P1-DP21+	GND	P1-DP20-	P1-DP20+
12	GND	P1-DP23-	P1-DP23+	GND	P1-DP22-	P1-DP22+	GND
13	P1-SE6	GND	P1-DP25-	P1-DP25+	GND	P1-DP24-	P1-DP24+
14	GND	P1-DP27-	P1-DP27+	GND	P1-DP26-	P1-DP26+	GND
15	P1-SE7	GND	P1-DP29-	P1-DP29+	GND	P1-DP28-	P1-DP28+
16	GND	P1-DP31-	P1-DP31+	GND	P1-DP30-	P1-DP30+	GND

Table 2

## P2 Connector Differential Pin Out

	Row G	Row F	Row E	Row D	Row C	Row B	Row A
1	P2-SE0	GND	P2-DP1-	P2-DP1+	GND	P2-DP0-	P2-DP0+
2	GND	P2-DP3-	P2-DP3+	GND	P2-DP2-	P2-DP2+	GND
3	P2-SE1	GND	P2-DP5-	P2-DP5+	GND	P2-DP4 -	P2-DP4+
4	GND	P2-DP7-	P2-DP7+	GND	P2-DP6-	P2-DP6+	GND
5	P2-SE2	GND	P2-DP9-	P2-DP9+	GND	P2-DP8-	P2-DP8+
6	GND	P2-DP11-	P2-DP11+	GND	P2-DP10-	P2-DP10+	GND
7	P2-SE3	GND	P2-DP13-	P2-DP13+	GND	P2-DP12-	P2-DP12+
8	GND	P2-DP15-	P2-DP15+	GND	P2-DP14-	P2-DP14+	GND
9	P2-SE4	GND	P2-DP17-	P2-DP17+	GND	P2-DP16-	P2-DP16+
10	GND	P2-DP19-	P2-DP19+	GND	P2-DP18-	P2-DP18+	GND
11	P2-SE5	GND	P2-DP21-	P2-DP21+	GND	P2-DP20-	P2-DP20+
12	GND	P2-DP23-	P2-DP23+	GND	P2-DP22-	P2-DP22+	GND
13	P2-SE6	GND	P2-DP25-	P2-DP25+	GND	P2-DP24-	P2-DP24+
14	GND	P2-DP27-	P2-DP27+	GND	P2-DP26-	P2-DP26+	GND
15	P2-SE7	GND	P2-DP29-	P2-DP29+	GND	P2-DP28-	P2-DP28+
16	GND	P2-DP31-	P2-DP31+	GND	P2-DP30-	P2-DP30+	GND

**Table 3**

## P2 Connector Single Ended Pin Out

	Row G	Row F	Row E	Row D	Row C	Row B	Row A
1	P2-SE04	P2-SE03	GND	P2-SE02	GND	P2-SE01	P2-SE00
2	P2-SE09	P2-SE08	GND	P2-SE07	GND	P2-SE06	P2-SE05
3	P2-SE14	P2-SE13	GND	P2-SE12	GND	P2-SE11	P2-SE10
4	P2-SE19	P2-SE18	GND	P2-SE17	GND	P2-SE16	P2-SE15
5	P2-SE24	P2-SE23	GND	P2-SE22	GND	P2-SE21	P2-SE20
6	P2-SE29	P2-SE28	GND	P2-SE27	GND	P2-SE26	P2-SE25
7	P2-SE34	P2-SE33	GND	P2-SE32	GND	P2-SE31	P2-SE30
8	P2-SE39	P2-SE38	GND	P2-SE37	GND	P2-SE36	P2-SE35
9	P2-SE44	P2-SE43	GND	P2-SE42	GND	P2-SE41	P2-SE40
10	P2-SE49	P2-SE48	GND	P2-SE47	GND	P2-SE46	P2-SE45
11	P2-SE54	P2-SE53	GND	P2-SE52	GND	P2-SE51	P2-SE50
12	P2-SE59	P2-SE58	GND	P2-SE57	GND	P2-SE56	P2-SE55
13	P2-SE64	P2-SE63	GND	P2-SE62	GND	P2-SE61	P2-SE60
14	P2-SE69	P2-SE68	GND	P2-SE67	GND	P2-SE66	P2-SE65
15	P2-SE74	P2-SE73	GND	P2-SE72	GND	P2-SE71	P2-SE70
16	P2-SE79	P2-SE78	GND	P2-SE77	GND	P2-SE76	P2-SE75

**Table 4**

## P3 Connector Differential Pin Out

	Row G	Row F	Row E	Row D	Row C	Row B	Row A
1	P3-SE0	GND	P3-DP1-	P3-DP1+	GND	P3-DP0-	P3-DP0+
2	GND	P3-DP3-	P3-DP3+	GND	P3-DP2-	P3-DP2+	GND
3	P3-SE1	GND	P3-DP5-	P3-DP5+	GND	P3-DP4 -	P3-DP4+
4	GND	P3-DP7-	P3-DP7+	GND	P3-DP6-	P3-DP6+	GND
5	P3-SE2	GND	P3-DP9-	P3-DP9+	GND	P3-DP8-	P3-DP8+
6	GND	P3-DP11-	P3-DP11+	GND	P3-DP10-	P3-DP10+	GND
7	P3-SE3	GND	P3-DP13-	P3-DP13+	GND	P3-DP12-	P3-DP12+
8	GND	P3-DP15-	P3-DP15+	GND	P3-DP14-	P3-DP14+	GND
9	P3-SE4	GND	P3-DP17-	P3-DP17+	GND	P3-DP16-	P3-DP16+
10	GND	P3-DP19-	P3-DP19+	GND	P3-DP18-	P3-DP18+	GND
11	P3-SE5	GND	P3-DP21-	P3-DP21+	GND	P3-DP20-	P3-DP20+
12	GND	P3-DP23-	P3-DP23+	GND	P3-DP22-	P3-DP22+	GND
13	P3-SE6	GND	P3-DP25-	P3-DP25+	GND	P3-DP24-	P3-DP24+
14	GND	P3-DP27-	P3-DP27+	GND	P3-DP26-	P3-DP26+	GND
15	P3-SE7	GND	P3-DP29-	P3-DP29+	GND	P3-DP28-	P3-DP28+
16	GND	P3-DP31-	P3-DP31+	GND	P3-DP30-	P3-DP30+	GND

Table 5

## P3 Connector Single Ended Pin Out

	Row G	Row F	Row E	Row D	Row C	Row B	Row A
1	P3-SE04	P3-SE03	GND	P3-SE02	GND	P3-SE01	P3-SE00
2	P3-SE09	P3-SE08	GND	P3-SE07	GND	P3-SE06	P3-SE05
3	P3-SE14	P3-SE13	GND	P3-SE12	GND	P3-SE11	P3-SE10
4	P3-SE19	P3-SE18	GND	P3-SE17	GND	P3-SE16	P3-SE15
5	P3-SE24	P3-SE23	GND	P3-SE22	GND	P3-SE21	P3-SE20
6	P3-SE29	P3-SE28	GND	P3-SE27	GND	P3-SE26	P3-SE25
7	P3-SE34	P3-SE33	GND	P3-SE32	GND	P3-SE31	P3-SE30
8	P3-SE39	P3-SE38	GND	P3-SE37	GND	P3-SE36	P3-SE35
9	P3-SE44	P3-SE43	GND	P3-SE42	GND	P3-SE41	P3-SE40
10	P3-SE49	P3-SE48	GND	P3-SE47	GND	P3-SE46	P3-SE45
11	P3-SE54	P3-SE53	GND	P3-SE52	GND	P3-SE51	P3-SE50
12	P3-SE59	P3-SE58	GND	P3-SE57	GND	P3-SE56	P3-SE55
13	P3-SE64	P3-SE63	GND	P3-SE62	GND	P3-SE61	P3-SE60
14	P3-SE69	P3-SE68	GND	P3-SE67	GND	P3-SE66	P3-SE65
15	P3-SE74	P3-SE73	GND	P3-SE72	GND	P3-SE71	P3-SE70
16	P3-SE79	P3-SE78	GND	P3-SE77	GND	P3-SE76	P3-SE75

Table 6

## P4 Connector Differential Pin Out

	Row G	Row F	Row E	Row D	Row C	Row B	Row A
1	P4-SE0	GND	P4-DP1-	P4-DP1+	GND	P4-DP0-	P4-DP0+
2	GND	P4-DP3-	P4-DP3+	GND	P4-DP2-	P4-DP2+	GND
3	P4-SE1	GND	P4-DP5-	P4-DP5+	GND	P4-DP4 -	P4-DP4+
4	GND	P4-DP7-	P4-DP7+	GND	P4-DP6-	P4-DP6+	GND
5	P4-SE2	GND	P4-DP9-	P4-DP9+	GND	P4-DP8-	P4-DP8+
6	GND	P4-DP11-	P4-DP11+	GND	P4-DP10-	P4-DP10+	GND
7	P4-SE3	GND	P4-DP13-	P4-DP13+	GND	P4-DP12-	P4-DP12+
8	GND	P4-DP15-	P4-DP15+	GND	P4-DP14-	P4-DP14+	GND
9	P4-SE4	GND	P4-DP17-	P4-DP17+	GND	P4-DP16-	P4-DP16+
10	GND	P4-DP19-	P4-DP19+	GND	P4-DP18-	P4-DP18+	GND
11	P4-SE5	GND	P4-DP21-	P4-DP21+	GND	P4-DP20-	P4-DP20+
12	GND	P4-DP23-	P4-DP23+	GND	P4-DP22-	P4-DP22+	GND
13	P4-SE6	GND	P4-DP25-	P4-DP25+	GND	P4-DP24-	P4-DP24+
14	GND	P4-DP27-	P4-DP27+	GND	P4-DP26-	P4-DP26+	GND
15	P4-SE7	GND	P4-DP29-	P4-DP29+	GND	P4-DP28-	P4-DP28+
16	GND	P4-DP31-	P4-DP31+	GND	P4-DP30-	P4-DP30+	GND

Table 7

## P4 Connector Single Ended Pin Out

	Row G	Row F	Row E	Row D	Row C	Row B	Row A
1	P4-SE04	P4-SE03	GND	P4-SE02	GND	P4-SE01	P4-SE00
2	P4-SE09	P4-SE08	GND	P4-SE07	GND	P4-SE06	P4-SE05
3	P4-SE14	P4-SE13	GND	P4-SE12	GND	P4-SE11	P4-SE10
4	P4-SE19	P4-SE18	GND	P4-SE17	GND	P4-SE16	P4-SE15
5	P4-SE24	P4-SE23	GND	P4-SE22	GND	P4-SE21	P4-SE20
6	P4-SE29	P4-SE28	GND	P4-SE27	GND	P4-SE26	P4-SE25
7	P4-SE34	P4-SE33	GND	P4-SE32	GND	P4-SE31	P4-SE30
8	P4-SE39	P4-SE38	GND	P4-SE37	GND	P4-SE36	P4-SE35
9	P4-SE44	P4-SE43	GND	P4-SE42	GND	P4-SE41	P4-SE40
10	P4-SE49	P4-SE48	GND	P4-SE47	GND	P4-SE46	P4-SE45
11	P4-SE54	P4-SE53	GND	P4-SE52	GND	P4-SE51	P4-SE50
12	P4-SE59	P4-SE58	GND	P4-SE57	GND	P4-SE56	P4-SE55
13	P4-SE64	P4-SE63	GND	P4-SE62	GND	P4-SE61	P4-SE60
14	P4-SE69	P4-SE68	GND	P4-SE67	GND	P4-SE66	P4-SE65
15	P4-SE74	P4-SE73	GND	P4-SE72	GND	P4-SE71	P4-SE70
16	P4-SE79	P4-SE78	GND	P4-SE77	GND	P4-SE76	P4-SE75

Table 8

## P5 Connector Differential Pin Out

	Row G	Row F	Row E	Row D	Row C	Row B	Row A
1	P5-SE0	GND	P5-DP1-	P5-DP1+	GND	P5-DP0-	P5-DP0+
2	GND	P5-DP3-	P5-DP3+	GND	P5-DP2-	P5-DP2+	GND
3	P5-SE1	GND	P5-DP5-	P5-DP5+	GND	P5-DP4 -	P5-DP4+
4	GND	P5-DP7-	P5-DP7+	GND	P5-DP6-	P5-DP6+	GND
5	P5-SE2	GND	P5-DP9-	P5-DP9+	GND	P5-DP8-	P5-DP8+
6	GND	P5-DP11-	P5-DP11+	GND	P5-DP10-	P5-DP10+	GND
7	P5-SE3	GND	P5-DP13-	P5-DP13+	GND	P5-DP12-	P5-DP12+
8	GND	P5-DP15-	P5-DP15+	GND	P5-DP14-	P5-DP14+	GND
9	P5-SE4	GND	P5-DP17-	P5-DP17+	GND	P5-DP16-	P5-DP16+
10	GND	P5-DP19-	P5-DP19+	GND	P5-DP18-	P5-DP18+	GND
11	P5-SE5	GND	P5-DP21-	P5-DP21+	GND	P5-DP20-	P5-DP20+
12	GND	P5-DP23-	P5-DP23+	GND	P5-DP22-	P5-DP22+	GND
13	P5-SE6	GND	P5-DP25-	P5-DP25+	GND	P5-DP24-	P5-DP24+
14	GND	P5-DP27-	P5-DP27+	GND	P5-DP26-	P5-DP26+	GND
15	P5-SE7	GND	P5-DP29-	P5-DP29+	GND	P5-DP28-	P5-DP28+
16	GND	P5-DP31-	P5-DP31+	GND	P5-DP30-	P5-DP30+	GND

Table 9

## P5 Connector Single Ended Pin Out

	Row G	Row F	Row E	Row D	Row C	Row B	Row A
1	P5-SE04	P5-SE03	GND	P5-SE02	GND	P5-SE01	P5-SE00
2	P5-SE09	P5-SE08	GND	P5-SE07	GND	P5-SE06	P5-SE05
3	P5-SE14	P5-SE13	GND	P5-SE12	GND	P5-SE11	P5-SE10
4	P5-SE19	P5-SE18	GND	P5-SE17	GND	P5-SE16	P5-SE15
5	P5-SE24	P5-SE23	GND	P5-SE22	GND	P5-SE21	P5-SE20
6	P5-SE29	P5-SE28	GND	P5-SE27	GND	P5-SE26	P5-SE25
7	P5-SE34	P5-SE33	GND	P5-SE32	GND	P5-SE31	P5-SE30
8	P5-SE39	P5-SE38	GND	P5-SE37	GND	P5-SE36	P5-SE35
9	P5-SE44	P5-SE43	GND	P5-SE42	GND	P5-SE41	P5-SE40
10	P5-SE49	P5-SE48	GND	P5-SE47	GND	P5-SE46	P5-SE45
11	P5-SE54	P5-SE53	GND	P5-SE52	GND	P5-SE51	P5-SE50
12	P5-SE59	P5-SE58	GND	P5-SE57	GND	P5-SE56	P5-SE55
13	P5-SE64	P5-SE63	GND	P5-SE62	GND	P5-SE61	P5-SE60
14	P5-SE69	P5-SE68	GND	P5-SE67	GND	P5-SE66	P5-SE65
15	P5-SE74	P5-SE73	GND	P5-SE72	GND	P5-SE71	P5-SE70
16	P5-SE79	P5-SE78	GND	P5-SE77	GND	P5-SE76	P5-SE75

Table 10

### P6 Connector Differential Pin Out

	Row G	Row F	Row E	Row D	Row C	Row B	Row A
1	P6-SE0	GND	P6-DP1-	P6-DP1+	GND	P6-DP0-	P6-DP0+
2	GND	P6-DP3-	P6-DP3+	GND	P6-DP2-	P6-DP2+	GND
3	P6-SE1	GND	P6-DP5-	P6-DP5+	GND	P6-DP4 -	P6-DP4+
4	GND	P6-DP7-	P6-DP7+	GND	P6-DP6-	P6-DP6+	GND
5	P6-SE2	GND	P6-DP9-	P6-DP9+	GND	P6-DP8-	P6-DP8+
6	GND	P6-DP11-	P6-DP11+	GND	P6-DP10-	P6-DP10+	GND
7	P6-SE3	GND	P6-DP13-	P6-DP13+	GND	P6-DP12-	P6-DP12+
8	GND	P6-DP15-	P6-DP15+	GND	P6-DP14-	P6-DP14+	GND
9	P6-SE4	GND	P6-DP17-	P6-DP17+	GND	P6-DP16-	P6-DP16+
10	GND	P6-DP19-	P6-DP19+	GND	P6-DP18-	P6-DP18+	GND
11	P6-SE5	GND	P6-DP21-	P6-DP21+	GND	P6-DP20-	P6-DP20+
12	GND	P6-DP23-	P6-DP23+	GND	P6-DP22-	P6-DP22+	GND
13	P6-SE6	GND	P6-DP25-	P6-DP25+	GND	P6-DP24-	P6-DP24+
14	GND	P6-DP27-	P6-DP27+	GND	P6-DP26-	P6-DP26+	GND
15	P6-SE7	GND	P6-DP29-	P6-DP29+	GND	P6-DP28-	P6-DP28+
16	GND	P6-DP31-	P6-DP31+	GND	P6-DP30-	P6-DP30+	GND

Table 11

### P6 Connector Single Ended Pin Out

	Row G	Row F	Row E	Row D	Row C	Row B	Row A
1	P6-SE04	P6-SE03	GND	P6-SE02	GND	P6-SE01	P6-SE00
2	P6-SE09	P6-SE08	GND	P6-SE07	GND	P6-SE06	P6-SE05
3	P6-SE14	P6-SE13	GND	P6-SE12	GND	P6-SE11	P6-SE10
4	P6-SE19	P6-SE18	GND	P6-SE17	GND	P6-SE16	P6-SE15
5	P6-SE24	P6-SE23	GND	P6-SE22	GND	P6-SE21	P6-SE20
6	P6-SE29	P6-SE28	GND	P6-SE27	GND	P6-SE26	P6-SE25
7	P6-SE34	P6-SE33	GND	P6-SE32	GND	P6-SE31	P6-SE30
8	P6-SE39	P6-SE38	GND	P6-SE37	GND	P6-SE36	P6-SE35
9	P6-SE44	P6-SE43	GND	P6-SE42	GND	P6-SE41	P6-SE40
10	P6-SE49	P6-SE48	GND	P6-SE47	GND	P6-SE46	P6-SE45
11	P6-SE54	P6-SE53	GND	P6-SE52	GND	P6-SE51	P6-SE50
12	P6-SE59	P6-SE58	GND	P6-SE57	GND	P6-SE56	P6-SE55
13	P6-SE64	P6-SE63	GND	P6-SE62	GND	P6-SE61	P6-SE60
14	P6-SE69	P6-SE68	GND	P6-SE67	GND	P6-SE66	P6-SE65
15	P6-SE74	P6-SE73	GND	P6-SE72	GND	P6-SE71	P6-SE70
16	P6-SE79	P6-SE78	GND	P6-SE77	GND	P6-SE76	P6-SE75

Table 12

## Power Wafer Current Rating

Using the table 5 (from ANSI/VITA 46.0 specification) below, the maximum power handling capacity of VPX 3U module can be calculated.

Power Wafer Current Rating for 30°C Temp. Rise (at Wafer Pad and Backplane Connector Contact Interfaces)						
Power plane thickness in plug-in module and backplane	2 ounce copper			1 ounce copper		
	3 wafers	2 wafers	1 wafer	3 wafers	2 wafers	1 wafer
Number of Wafers across which power is dissipated	3 wafers	2 wafers	1 wafer	3 wafers	2 wafers	1 wafer
Current Allowed per pad (A)	6	8	11.5	5	7	11
Current Allowed per wafer (A)	12	16	23	10	14	22
Total Current Allowed per connector (A)	36	32	23	30	28	22

**Table 13**