

Description

The 5-slot switchless mesh VXS backplane allows the direct connection of up to 3 node cards without the requirement for a switch card. This unique arrangement could be used to develop and test communication between end-point cards, support small system needs and allow the demonstration of VXS node cards.

This implementation takes advantage of the fact that VXS payload cards have two fabric channels that allow them to communicate with either fabric switch A or fabric switch B. With the interconnect paths "wired" into the backplane, each card in a three card set, could each communicate directly with the the two cards with out the need for a separate fabric switch.

Features

- Conforms to VITA 41.0 VXS backplane specifications
- High speed MultiGig RT-2 connector over P0
- Plenty of power bugs for 3.3V, 5V, 12V and GND
- Point-to-point connections which do not require use of switch cards
- Single Star, Dual Star, Dual-Dual Star, and Replicated versions available
- Two standard VME64x slots

Board Specifications

- 10-layer board
- 2 oz. copper power and ground
- PCB UL listed 94V-0
- PCB FR-4 or equivalent
- PCB .125" thick

Mechanical Specifications

- 5 slots, other sizes available
- 7U height
- 160-pin, class II VME connectors
- Multi-Gig RT-2 P0 connectors



Close-up of MultiGig RT-2 Connectors



Close-up of Power Bugs

VXS Backplanes - Mesh

Line Drawing

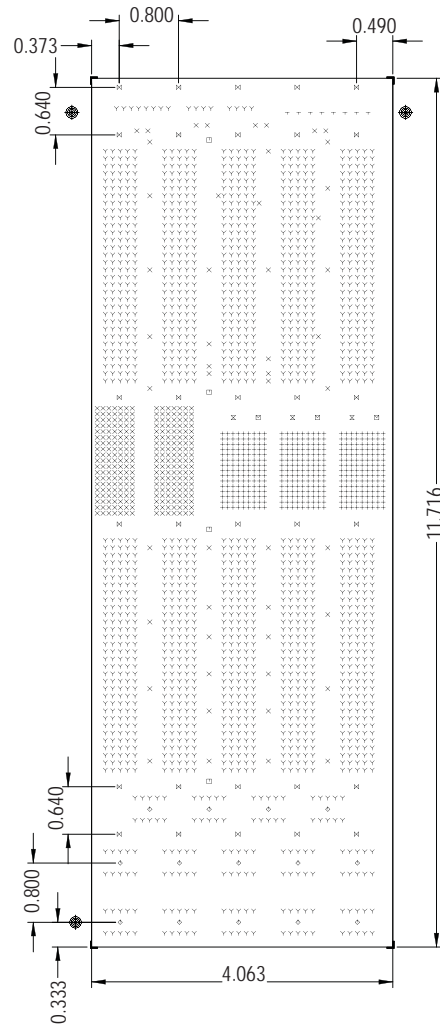

ORDER INFORMATION

Total Slots

Switch Card Slots

Payload Slots

Part Number

5

0

3 meshed payload, 2 legacy VME64x

101VXSM705

VXS Backplanes - Mesh

Product Configurations

(Example: 101VXSM705-0621R)

101	Product	Form	Slots	- _ _ _ _ Configuration
	<p>Product VXS = VITA 41 Compatible 7U</p> <p>Topology M = Mesh</p> <p>02-21 = Slots</p> <p>Configuration</p> <p>Power Interface _____</p> <p>0 = 10 pin power tap with 6/32 screw 1 = M4 threaded stud 2 = 10 pin power taps with busbar kit 9 = Custom [9 _ _ _ sequential numbers] X = Not applicable</p> <p>J1 Connectors and Shrouds _____</p> <p>0 = Not applicable 1 = Not applicable 2 = 160 pin 17mm with shrouds, all slots 3 = 160 pin 13mm with shrouds, all slots 4 = 160 pin 13mm without shrouds, all slots 5 = 160 pin 17mm without shrouds, all slots 6 = 160 pin 5mm without shrouds, all slots 7 = Not applicable 8 = 160 pin 17mm slot 1, 5mm all other slots X = Not applicable</p> <p>J2 Connectors and Shrouds _____</p> <p>0 = Not applicable 1 = Not applicable 2 = 160 pin 17mm with shrouds, all slots 3 = 160 pin 13mm with shrouds, all slots 4 = 160 pin 13mm without shrouds, all slots 5 = 160 pin 17mm without shrouds, all slots 6 = 160 pin 5mm without shrouds, all slots X = Not applicable</p> <p>J0 Connectors and Shrouds _____</p> <p>0 = No J0 connector 1 = J0 [9 x 15 connector] 2 = J0, RJ0, rear alignment pin and header (if VME64x slots present, J0 and shrouds inst.) X = Not applicable</p> <p>RoHS Compliance _____</p> <p>R = RoHS compliant</p>			

Common Configurations

VXS Backplanes - Mesh

Pin Connectivity

3 Slot Fabric Connectivity					
	Slot Number				
	1	2	3	4	5
Channel A	n/a	n/a	4a	3a	3b
Channel B	n/a	n/a	5a	5b	4b

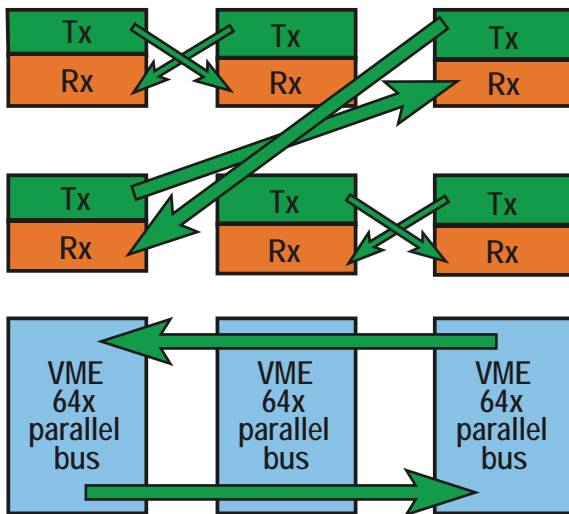

VXS Backplanes - Mesh

5-Slot

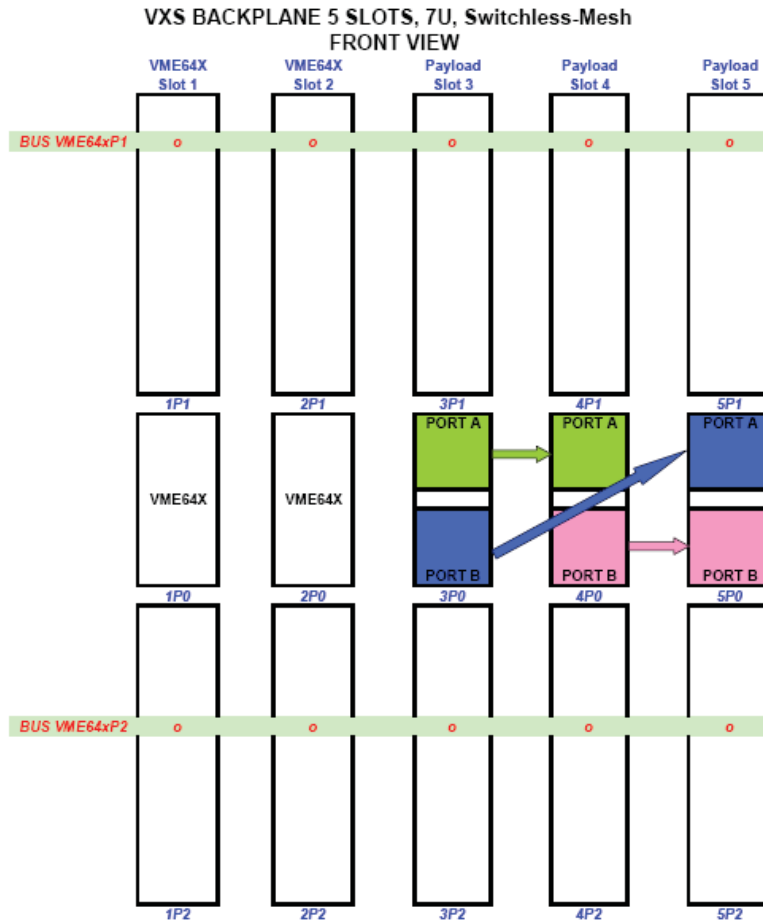

Legend: The Payloads Slots are connected one to each other as follows:

- # Port A from Slot 3 is connected with Port A from Slot 4
- # Port B from Slot 3 is connected with Port A from Slot 5
- # Port B from Slot 4 is connected with Port B from Slot 5

VXS Backplanes - Mesh

5-Slot

System Monitoring : P1 (8-way Header) having the pin assignment according to the figure below.

P1	
1	GND
2	+5V
3	ACFAIL
4	SYSFAIL
5	SYSRESET
6	+3.3V
7	+12V
8	-12V

Specifications

- VITA 1.7-2003 Increased Current Level for 96 Pin & 160 Pin DIN/IEC Connector
- VITA 41.0-200x VXS VMEbus Switched Serial Standard
- VITA 41.10-2003 Live Insertion System Requirements for VITA 41 Boards Trial Use Standard
- VITA 41.11-2005 Rear Transition Module Standard for VXS VMEbus Switched Serial Payload
- ANSI/VITA 38-2003 System Management Draft Standard
- ANSI/VITA 1.1-1997 VME64x Standard as modified by VITA 41.0 (P0/J0 connector and Switch Slots)
- ANSI/VITA 1.5-2003 2eSST (Source Synchronous Transfer)

Related Products from Elma Electronic:

- System Platforms – need a chassis for your backplane?
- VXS Embedded Computing Products – SBCs, Switches, Shelf Managers, and More.

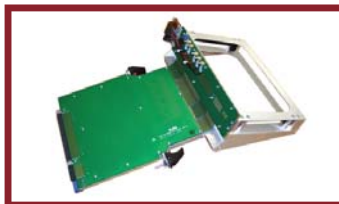

Did you know we also offer with this VXS backplane:

- VXS Extenders, RTMs, test modules
- Thermal or backplane simulation/test, paint/silkscreen, customization, integration

System
Platforms

Backplanes

Enclosures &
Components

Cabinets

Rotary
Switches

ELMA
Your Solution Partner