

## VXS BACKPLANES-SWITCHLESS MESH



### FEATURES

- Conforms to VITA 41.0 VXS backplane specifications
- High-speed Multi-Gig RT-2 connector for up to 6.4 Gbps signals over P0
- Plenty of power bugs for 3.3V, 5V, 12V and GND
- Point-to-point connections which do not require use of switch cards
- Single Star, Dual Star, Dual-Dual Star, and Replicated versions available
- Two standard VME64x slots

### BOARD SPECIFICATIONS

- 10-layer board
- 2 oz. copper power and ground
- PCB UL listed 94V-0
- PCB FR-4 or equivalent
- PCB .125" thick

### MECHANICAL SPECIFICATIONS

- 5 slots, other sizes available
- 7U height
- 160-pin, class II VME connectors
- Multi-Gig RT-2 P0 connectors

### DESCRIPTION

The 5-slot switchless mesh VXS backplane allows the direct connection of up to 3 node cards without the requirement for a switch card. This unique arrangement could be used to develop and test communication between end-point cards, support small system needs and allow the demonstration of VXS node cards.

This implementation takes advantage of the fact that VXS payload cards have two fabric channels that allow them to communicate with either fabric switch A or fabric switch B. With the interconnect paths "wired" into the backplane, each card in a three card set, could each communicate directly with the the two cards with out the need for a separate fabric switch.

# VXS BACKPLANES-SWITCHLESS MESH

## LINE DRAWING

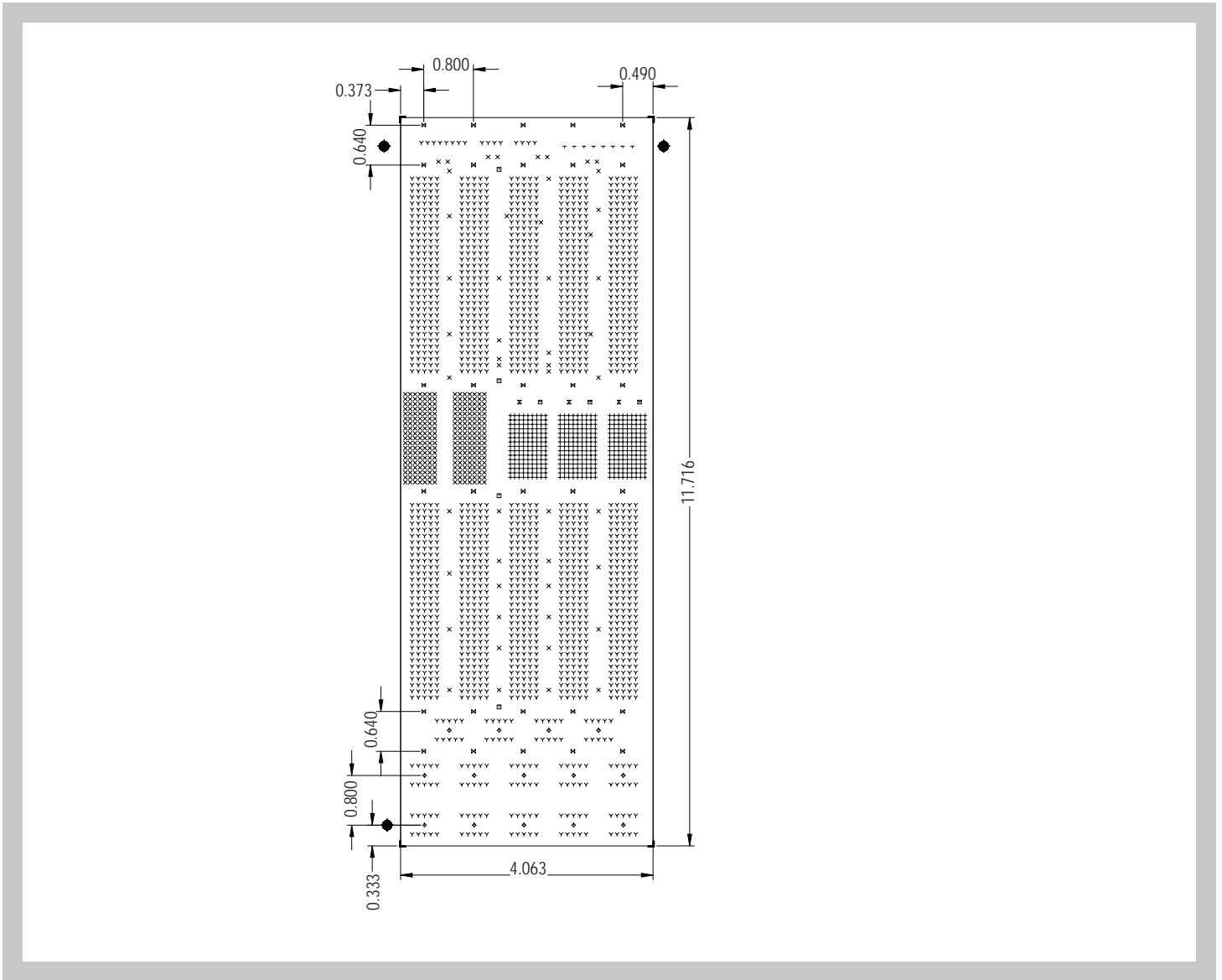

## ORDER INFORMATION

**Total Slots**

5

**Switch Card Slots**

0

**Payload Slots**

3 meshed payload, 2 legacy VME64x

**Part Number**

101VXSM705

# VXS BACKPLANES-SWITCHLESS MESH

## PIN CONNECTIVITY

3 Slot Fabric Connectivity					
	Slot Number				
	1	2	3	4	5
Channel A	n/a	n/a	4a	3a	3b
Channel B	n/a	n/a	5a	5b	4b

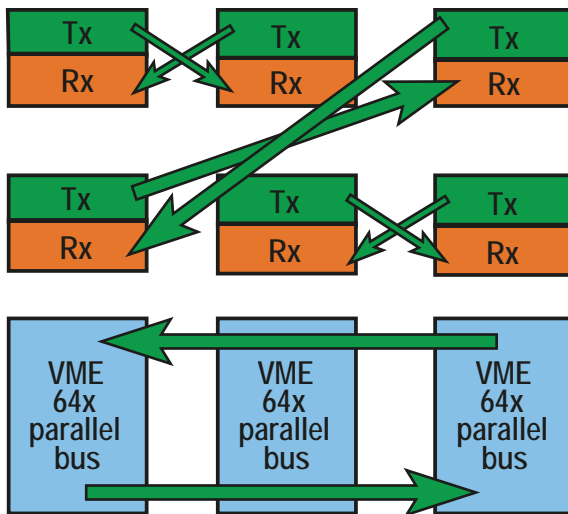

# VXS BACKPLANES-SWITCHLESS MESH

## 5-SLOT

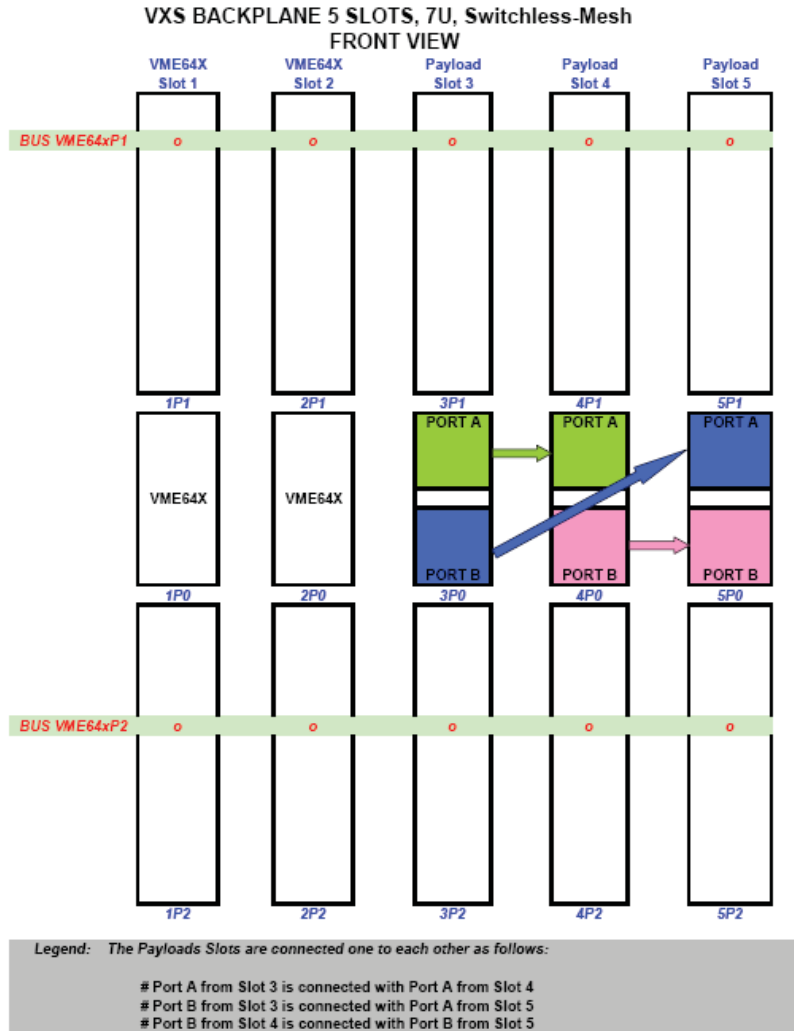

The power insertion area is below the signal slots above the bottom-mounting rail.



Power bugs

---

# VXS BACKPLANES-SWITCHLESS MESH

---

## 5-SLOT

System Monitoring : P1 (8-way Header) having the pin assignment according to the figure below.

P1	
1	GND
2	+5V
3	ACFAIL
4	SYSFAIL
5	SYSRESET
6	+3.3V
7	+12V
8	-12V

---

## SPECIFICATIONS

- VITA 1.7-2003 Increased Current Level for 96 Pin & 160 Pin DIN/IEC Connector
- VITA 41.0-200x VXS VMEbus Switched Serial Standard
- VITA 41.10-2003 Live Insertion System Requirements for VITA 41 Boards Trial Use Standard
- VITA 41.11-2005 Rear Transition Module Standard for VXS VMEbus Switched Serial Payload
- ANSI/VITA 38-2003 System Management Draft Standard
- ANSI/VITA 1.1-1997 VME64x Standard as modified by VITA 41.0 (P0/J0 connector and Switch Slots)
- ANSI/VITA 1.5-2003 2eSST (Source Synchronous Transfer)